

AGCO Power 84 CTIM-4V 8352 62734



Marine Engine

Technical data

Displacement	8,4 l
Number of cylinders	6 in line
Cylinder head	Cross-flow
Valves/cyl	2 inlet and 2 exhaust
Aspiration	Turbocharged, air to water intercooled
Rotation facing flywheel	Anticlockwise
Injection system	Bosch Common Rail
Engine management	SisuTronic EEM3 with Bosch EDC7
Fulfills IMO and EC marine engine exhaust emission standards	

Engine Performance According to ISO 14396

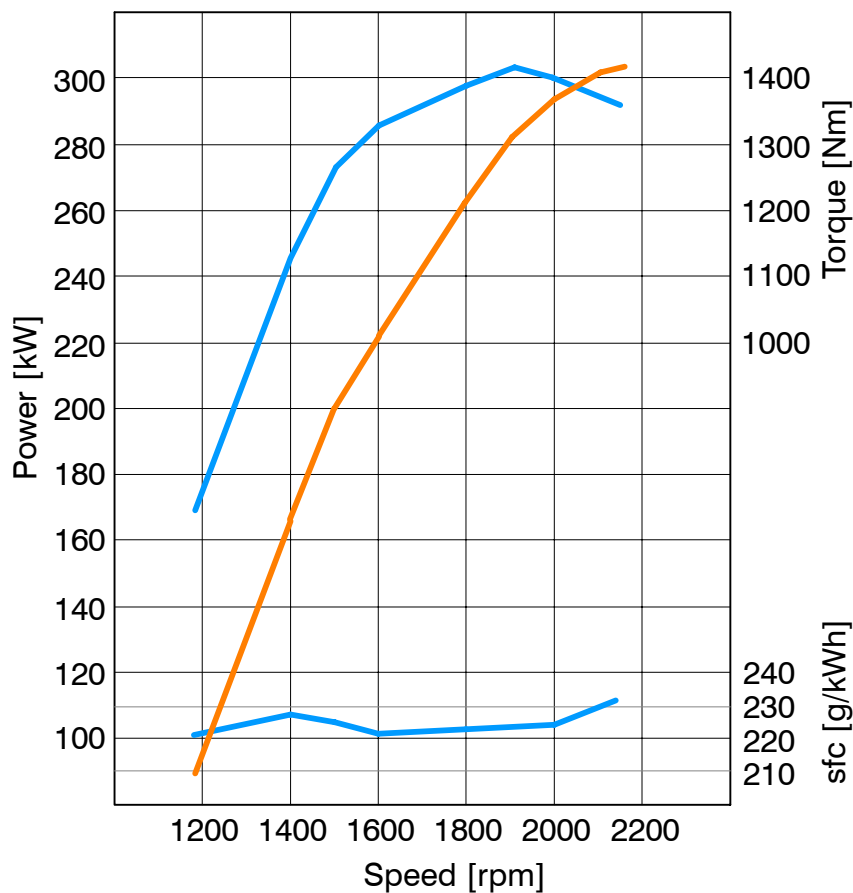

Standard Equipment

- Flywheel with SAE 2 housing
- 2-pole 12V electrical system, 65A alternator
- Freshwater-cooled exhaust manifold
- Integrated heat exchanger
- Seawater-cooled intercooler
- Gear-driven seawater pump
- Single-stage oil-wetted air cleaner
- Complete instrument panel and engine wiring harness

Optional Equipment

- Flywheel with SAE 1 or SAE 3 housing
- 2-pole 24V electrical system, 60A alternator
- 2-pole 12V/100A or 24V/110A alternator
- Keel cooling system
- Expansion tank
- Block heater, 230V or 120V system
- Exhaust elbow, dry or wet
- Closed crankcase ventilation system
- Air filter and rain cap
- Engine brackets and rubber mountings
- Oil drain pump

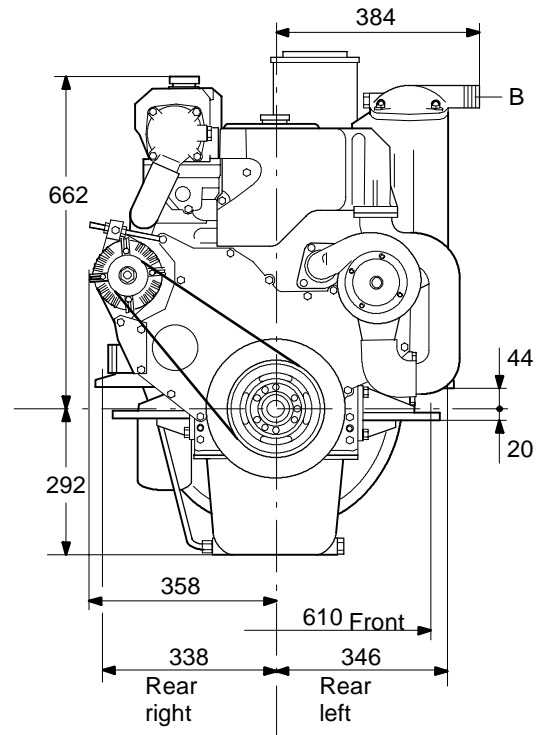
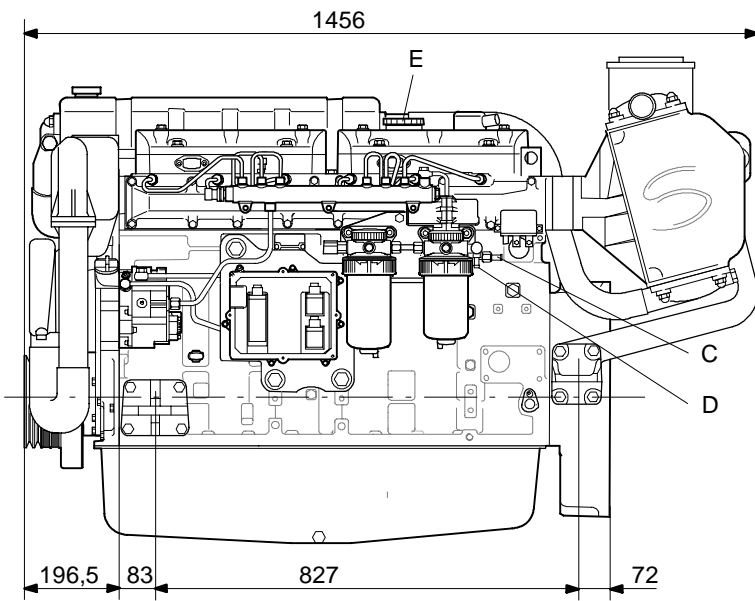

Note! Engine brackets are optional equipment

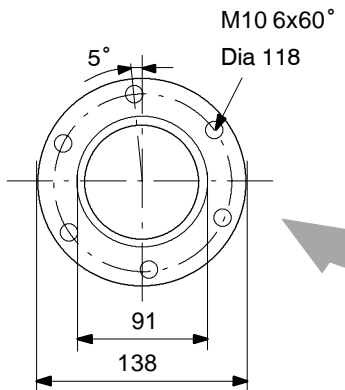

Exhaust outlet flange 8368 64433

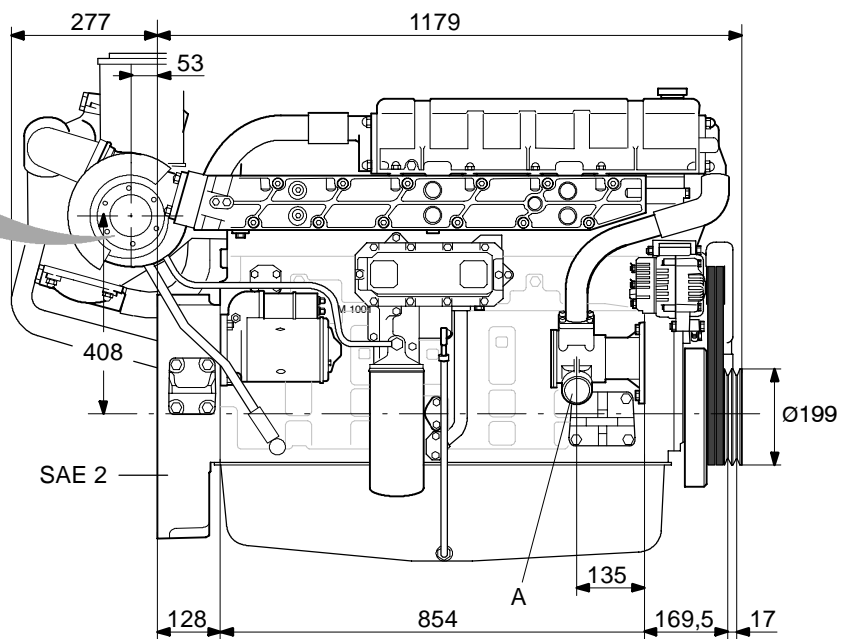

- A COOLING WATER INLET O. D. 60
- B COOLING WATER OUTLET O. D. 47
- C FUEL RETURN TO TANK O. D. 10
- D FUEL FROM TANK O. D. 10
- E OIL FILLER CAP

AGCO Power Oy
Linnavuori, Finland
Tel +358 3 3417 111
Fax+358 3 3417 333
www.agcopower.com

